

► SPECIFICATIONS

4000D Front Tip / Manual Swivel

MACH415

MACH416

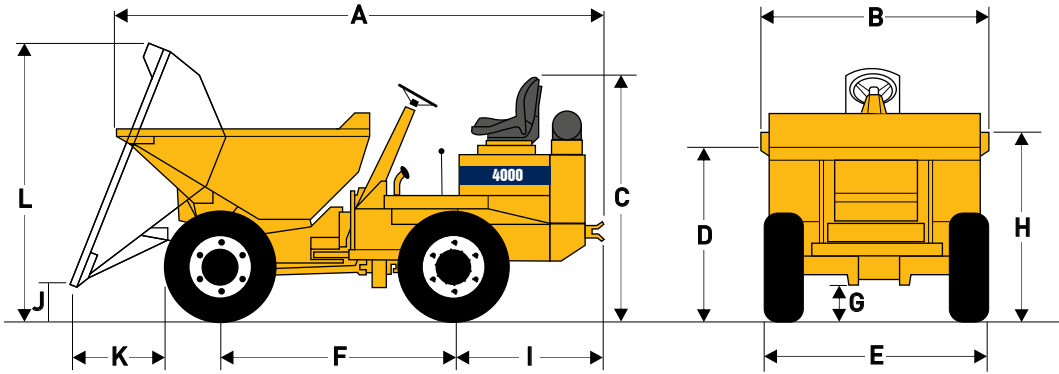

Dimension (mm)

A	3381
B	1763
C	1812
D	1249
E	1744
F	1836
G	276
H	1305
I	918
J	269
K	482
L	2023

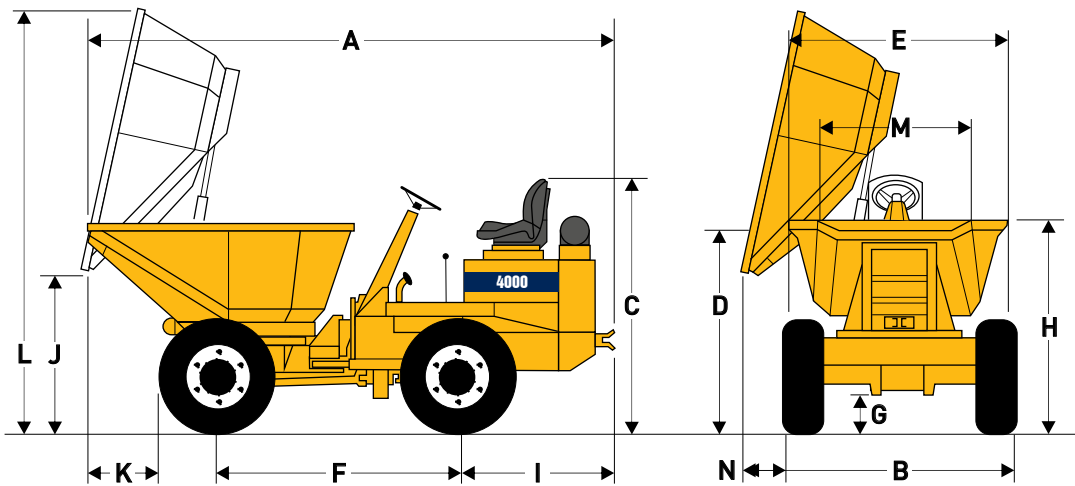

Dimension (mm)

A	3561
B	1744
C	1812
D	1378
E	1696
F	1836
G	276
H	1469
I	918
J	863
K	407
L	2705
M	580
N	108

► SPECIFICATIONS

4000D Front Tip / Manual Swivel

MACH415
MACH416

Capacities	Front Tip	Swivel Skip
Max. safe load	2000 kg	2000 kg
Heaped	1530 litres	1330 litres
Struck	1076 litres	991 litres
Water	906 litres	779 litres

Engine

Deutz F02L2011, 20.2 kW (27.1 bhp) at 2500 rpm, 2-cylinder air-cooled electric starting diesel. Max. torque 86Nm at 1700rpm. Emission compliancy stage II. Heavy-duty cyclonic air cleaner. Hourmeter.

Electrical System

Wiring harness contained within conduits and all electrical components water resistant to IP65 standards. Warning lights and audible alarm for oil pressure, battery charge and oil temperature.

Transmission

Heavy duty gearbox, three forward, one reverse, constant mesh change on the move with nickel chrome case hardened gears. Drive through 240 mm dia spring-damped heavy duty clutch. Transfer reduction box.

Speeds	1	3.7 km/h
	2	8.6 km/h
	3	15.9 km/h
	Reverse	4.1 km/h

Tyres	10.0/75 x 15 10 ply Load/Speed Index 123 A8 Sand tyre
-------	--

Brakes and Axles

Long-life totally enclosed multiplate oil-immersed discs mounted on front axle effective on all four wheels. Automatic adjustment for wear. Hand-operated parking brake. Heavy-duty axles with epicyclic reduction and fully floating halfshafts.

Chassis

Front and rear chassis constructed from deep section folded steel plate, with three-point Kinglink giving centre articulation and oscillation.

Skips

Hydraulically operated, double acting tipping ram, 5 mm steel plate all round, mouth and sides reinforced with box sections. No material traps. Swivel skip 180° manual rotation on bearing turntable.

Steering & Hydraulics

Hydraulic priority power steering. Return line filtration for all services and large capacity strainer in the tank to give full circuit protection.

Tank capacities	Fuel	23 litres
	Hydraulic	23 litres

Turning Circle	9.2 m
----------------	-------

Shipping Cube	Front Tip	10.8 m ³
	Swivel Skip	11.3 m ³

Unladen Weight	1840 kg	1900 kg
----------------	---------	---------

Optional Extras

Track grip tyres. Reverse alarm.

Distributor



Thwaites Ltd. Leamington Spa, Warwickshire CV32 7NQ, England
Tel +44 (0)1926 422471 Fax +44 (0)1926 337155
www.thwaitesdumpers.co.uk



We reserve the right to change all specifications without prior notice.
Printed in England 09/2017