

► SPECIFICATIONS

2 Tonne Front Tip Hydrostatic

MACH2076

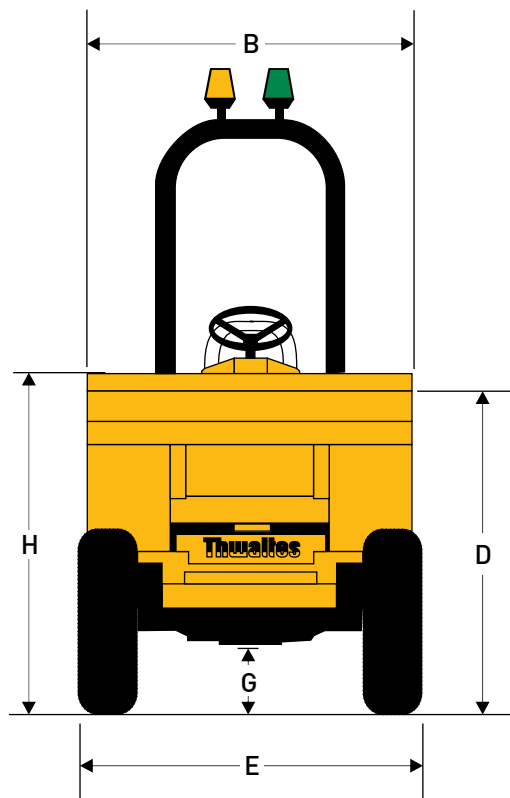
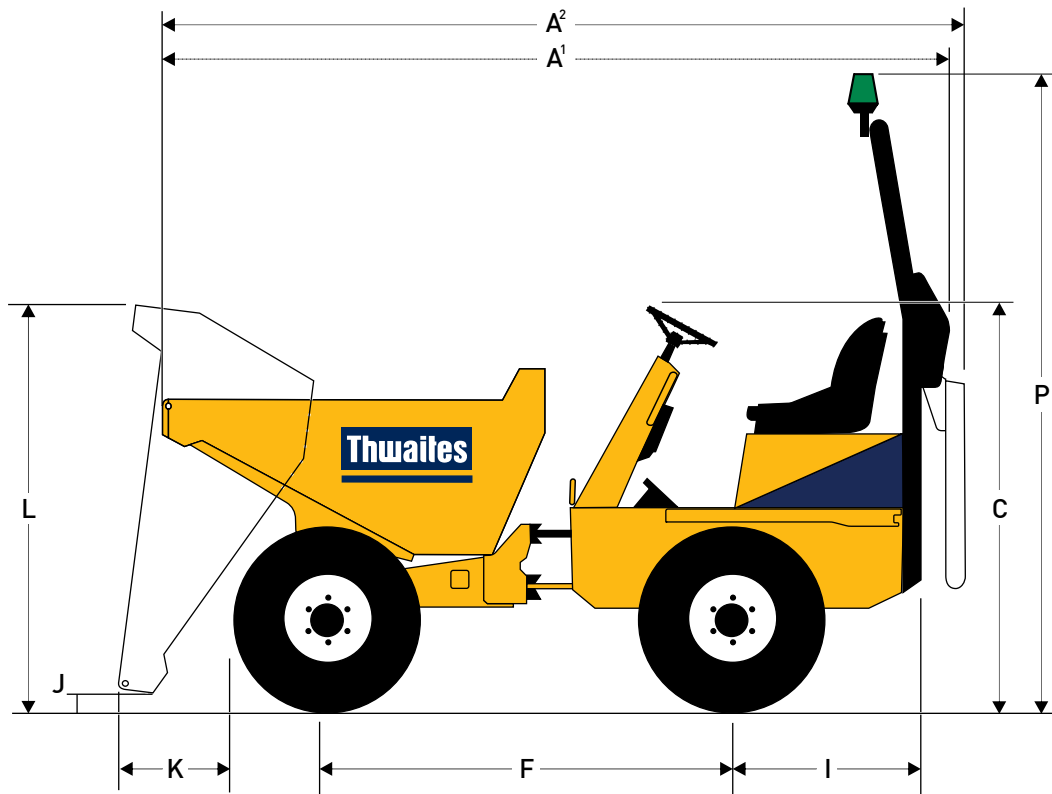

Dimension (mm)

A ¹	3603
A ²	3768
B	1490
C	1926
D	1346
E	1488
F	1850
G	282
H	1431
I	1042
J	278
K	594
L	2001
P	3053

2 Tonne Front Tip Hydrostatic

MACH2076

Capacities	Max safe load	2000 kg
	Heaped	1240 litres
	Struck	970 litres
	Water	850 litres

Engine

Yanmar 3TNV88-BWWA, 18.4 kW/24.6 bhp (nett) at 2000 rpm, 3-cylinder water-cooled direct-injection diesel. Max. torque 107 Nm at 1200 rpm (78.9 lbf ft). Electric starting, hour meter, battery isolator switch and heavy-duty cyclonic air cleaner positioned within the lockable engine compartment.

Noise Levels

Operator's ear 84 LpA, airborne sound power level 101 LwA (to 2000/14/EC).

Transmission

Hydrostatic with high/low speed range and forward/reverse direction controlled by one column-mounted lever. Inching facility for precise manoeuvres in restricted areas activated by first push on brake pedal.

Speeds	Forward and Reverse	
	Low	0-5.5 km/h (3.4 mph)
	High	0-15.0 km/h (9.3 mph)

Tyres	255/75 x 15.3
	Load/Speed Index 107 A8
	Track grip tread

Brakes and Axles

Totally enclosed multiplate oil-immersed discs mounted on rear axle effective on all four wheels. Automatic adjustment for wear. Hand-operated parking brake, spring applied hydraulically released brakes (SAHR). Heavy-duty axles with epicyclic reduction and fully floating halfshafts. Reduction gearbox integral with rear axle differential housing.

Kinglink Chassis

Front and rear chassis constructed from deep section folded steel plate, with three-point Kinglink giving centre articulation and oscillation for better stability, traction and extra safety on site. Remote greasing point provided for lubrication of top Kinglink articulation pin.

Skip

Hydraulically operated, constructed from 5 mm steel, fully welded, mouth and sides of skip reinforced with box sections giving greater strength to minimise skip damage. No material traps.

Seating & Controls

Adjustable suspension seat, accessible from both sides. Audible warning device at key start 'on' position. Super-bright warning lights for all critical functions. Electric horn. Large pedal pads with handbrake and hydraulic controls ready to hand.

Service Access

Lockable 3-sided cover opens to provide easy access from ground level to engine service points, all located on the same side. Moulded diesel and steel hydraulic tanks positioned low in the chassis side members, permitting access to the filler caps from ground level

Electrics

Wiring harness contained within conduits and all electrical components water-resistant to IP65/67 standards.

Steering and Hydraulics

Hydraulic priority power steering. Filter mounted on the top of the tank accessible from ground level. Combined suction and return filtration for all services. Hydraulic test points fitted as standard.

Tank Capacities	Fuel	24.5 litres
	Hydraulic	25.0 litres

Shipping Cube	10.6 m ³ (with folded ROPS)
----------------------	--

Unladen Weight	1920kg
-----------------------	--------

Clearance Diameter	7.5m
---------------------------	------

Standard Equipment

ROPS frame, Towing bracket, LED Beacons (Amber) & (Green). Reverse alarm,

Optional Extras

Full LED road lighting Incl. DRL (Daylight Running Lights), Road mirrors, Wheel Nut Indicator

Distributor



Thwaites Ltd. Leamington Spa, Warwickshire CV32 7NQ, England
 Tel +44 (0)1926 422471 Fax +44 (0)1926 337155
 www.thwaitesdumpers.co.uk



We reserve the right to change all specifications without prior notice.
 Printed in England
 01/2020